

The FG 400 series combines a 24V brushless DC drive motor in a rotor-less configuration with a high precision mag drive MG or PG series gear pump to deliver a high end system capable of handling fluids in the most demanding applications.

The service life of the unit, due to fewer moving parts and to the excellent balance of the system, is greatly extended compared to the traditional pump-motor units. The integration of the pump, motor and variable speed controller provides an electromagnetically coupled, leak free fluidic system with a high degree of versatility. The extreme accuracy of the design and of the finishing allows the unit to deliver a smooth and pulsation free flow in all conditions. Different materials are available for a wide array of fluids.



A BUILT-IN RELIEF VALVE IS AVAILABLE UPON REQUEST

- Brushless motor 24 V
- Ceramic Wearing Plates
- Ceramic Shaft
- Flat Gasket PTFE

TECHNICAL INFORMATION

Pump housing material	AISI 316L or PPS	Speed range	from 300 to 5000 rpm
Gears and bushing material	Peek/PTFE	Motor IP protection	IP 52
Ports	1/8" GAS or NPT	Unit weight	AISI 316L 910g/2lb - PPS 550g/1.2lb
Max vacuum	724 mmHg/28.5 inHg	Motor type	50 W
Wet lift with water*	~ 8 m/26.2 ft	Insulation class	24 V BLDC
Max static pressure	20 bar/290 psi	Max output power	F

OPERATING RANGE

Max ambient temperature	95 °C/203 F	70 mNm/9.9 in-oz at 3500 rpm	100 mNm/14.1 in-oz at 3500 rpm
Fluid temperature	30 mNm/4.2 in-oz at 5000 rpm	55 °C/131 F	40 °C/104 F
Min ambient temperature	40 °C/104 F	70 °C/150 F	40 °C/104 F
Max torque		5°C/41 F	

DIMENSIONS

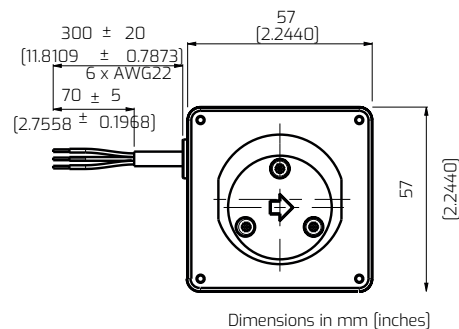
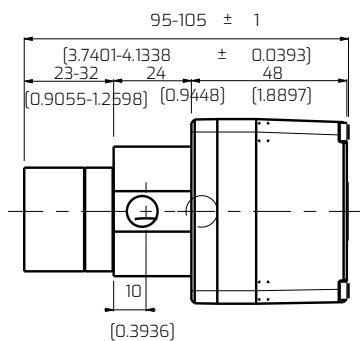

TECHNICAL INFORMATION

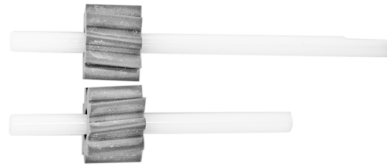

- Ceramic shaft
- Peek / ceramic gears

PERFORMANCE CURVES

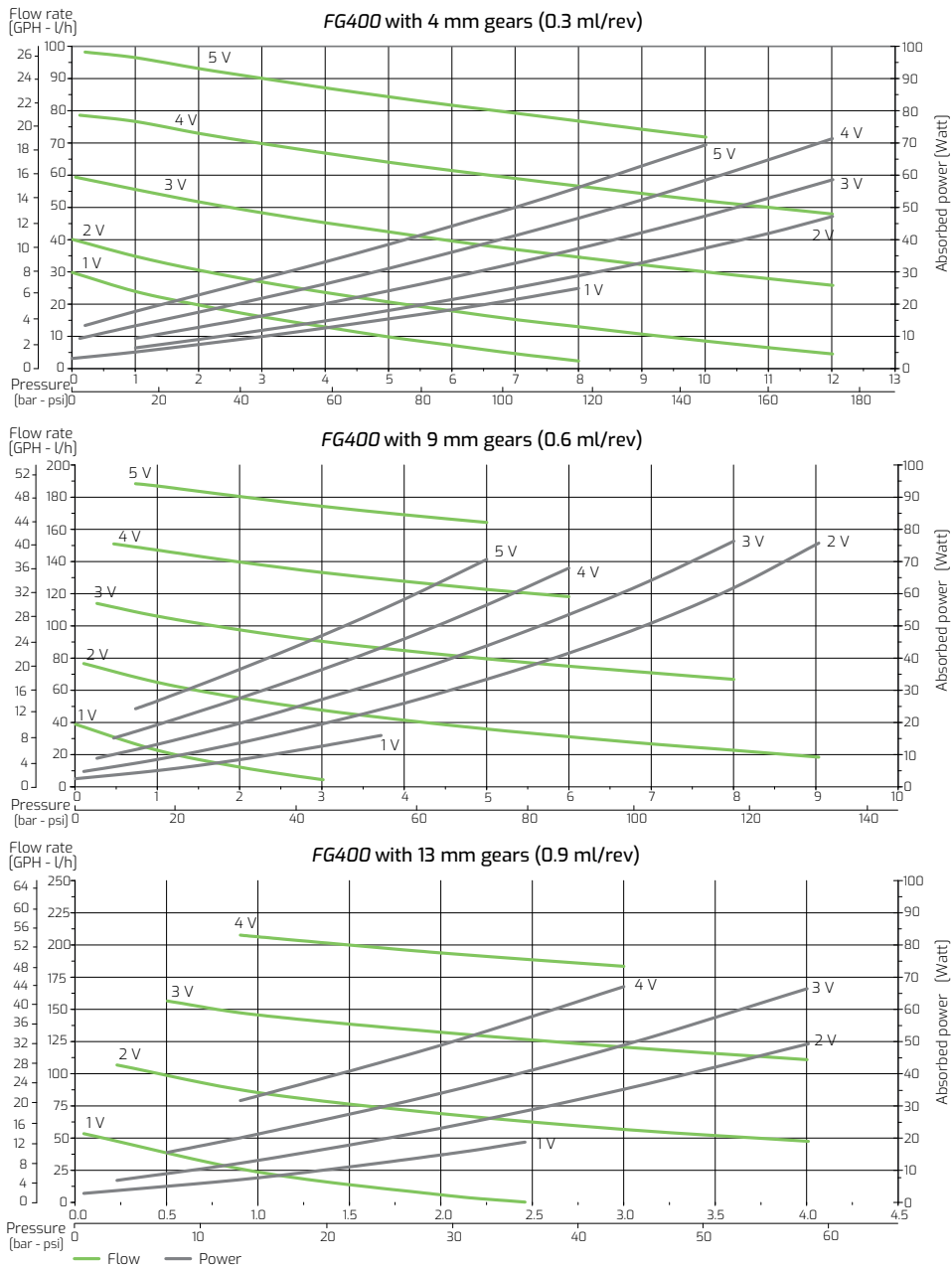

Note: Characteristics with water at 20 °C (68 F) and without relief valve. Fluids different from water must be validated by the Customer. Temperature requirements different from ambient temperature must be mentioned on the order. Different materials are available upon request. Use a filter before the pump inlet no larger than 10 micron. Fluid-o-Tech reserves the right to alter the specifications indicated in this catalogue at any time and without prior notice.

