

There are applications where the liquids involved are very difficult to handle and working solutions are hard to find and require a great financial investment. The PG300 series is Fluid-o-Tech®'s reply to such requirements. Made to give the same high level of performance as the MG300 series, the PG300 series pumps are built in a special grade of PPS to offer the greatest versatility and quality of material while allowing for exceptional mechanical characteristics. The gears are available in Peek and PTFE. The elastomers are available in a comprehensive range of materials to allow usage in the widest variety of applications. The PG300 series offers mag drive coupling with ferrite or rare earths magnets.



Available upon request:

- Built-in relief valve
- Rare earths driven magnet



"MAIN APPLICATIONS"

- Medical and surgical equipment
- Hemodialysis apparatus
- Laser apparatus
- Ink-Jet printing systems
- Cooling systems
- Laboratory instrumentation
- Water treatment
- Sampling
- Food processing equipment
- Sanitization

TECHNICAL INFORMATION

Pump housing material	PPS	Max static pressure	20 bar/290 psi
Gears and bushing materials	Peek™/PTFE™	Temperature range	-45 to 60°C/-49 to 140F
Ports	1/8" GAS or NPT	Max vacuum	724 mmHg/28.5 inHg
Pump weight (PG317)	230 g (0.7 lbs)	Wet lift with water*	~ 8m/26.2 ft
Speed limit	5000 rpm	Max instantaneous gradient of fluid	45°C/113°F

DIMENSIONS

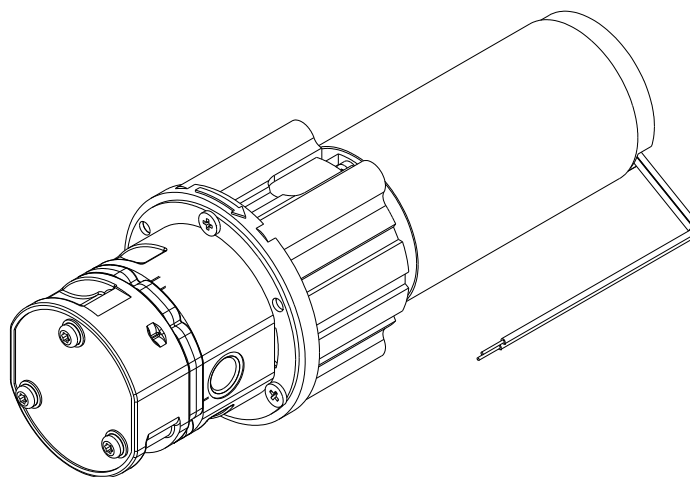

PERFORMANCE CURVES

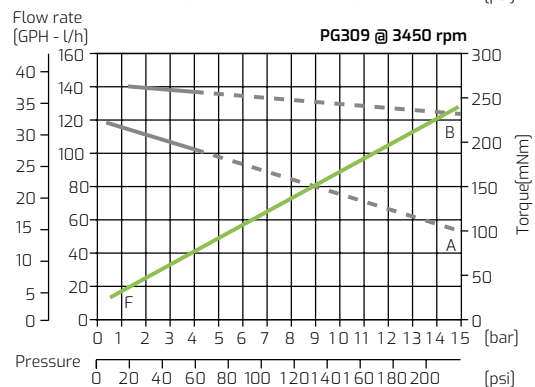
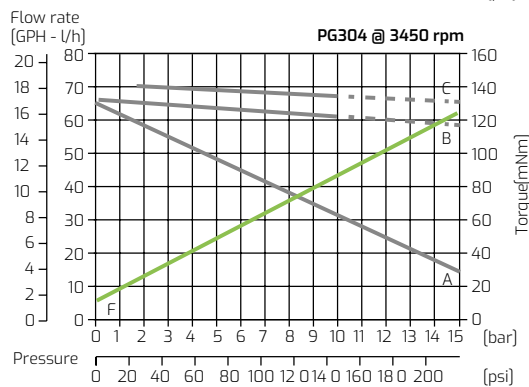
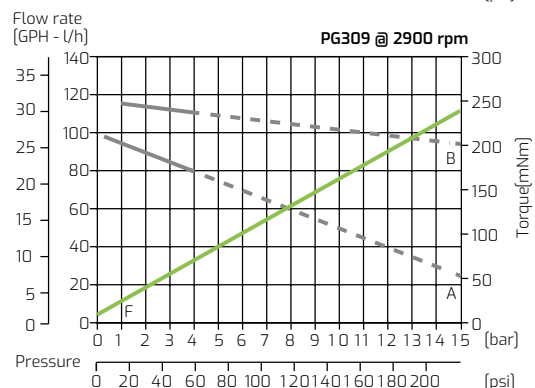
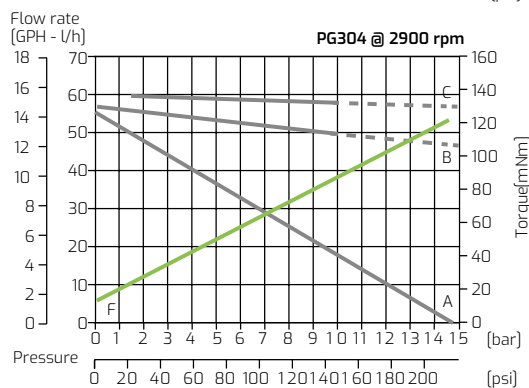
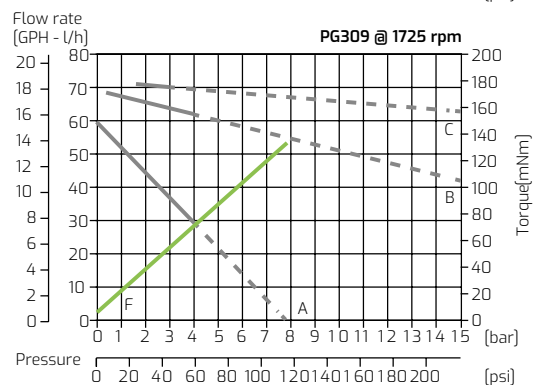
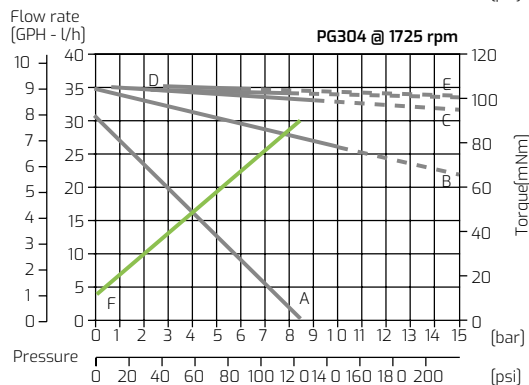
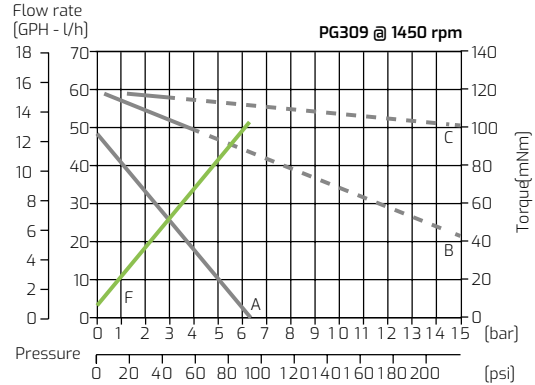
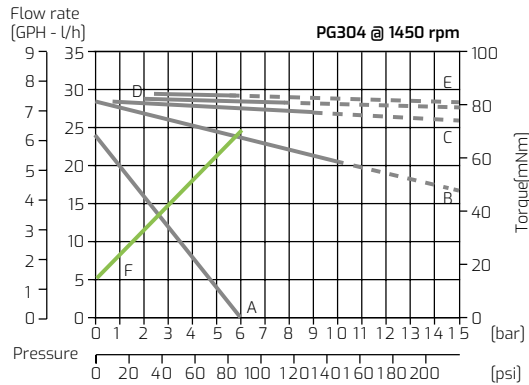

— Operating range with ferrite driving magnet
 - - - Operating range with rare earth driving magnet
 — Torque

A = 1 cP B = 20 cP C = 75 cP D = 180 cP E = 210 cP F = 1 cP Torque

Note: Characteristics with water at 20 °C (68 F) and without relief valve. Fluids different from water must be validated by the Customer. Temperature requirements different from ambient temperature must be mentioned on the order. Different materials are available upon request. Use a filter before the pump inlet no larger than 10 micron



PERFORMANCE CURVES

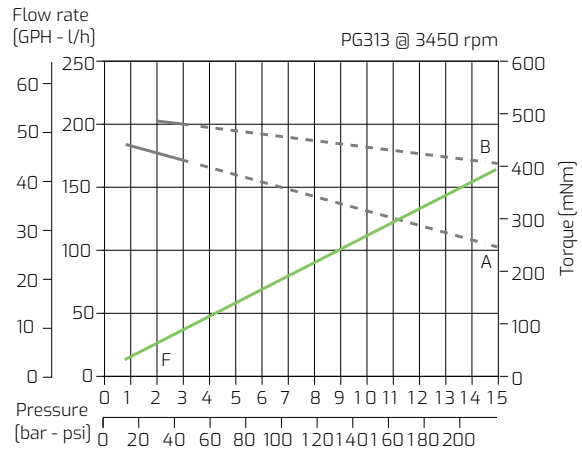
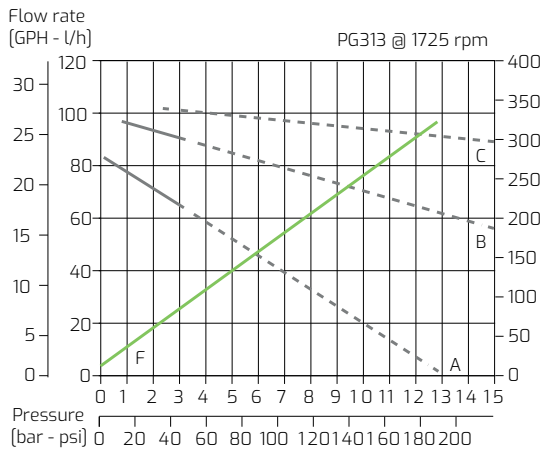
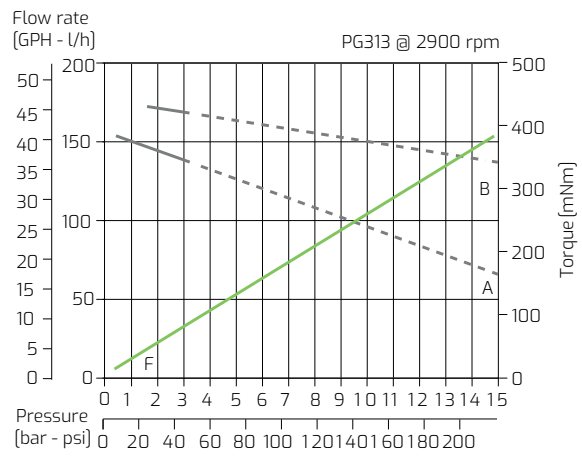
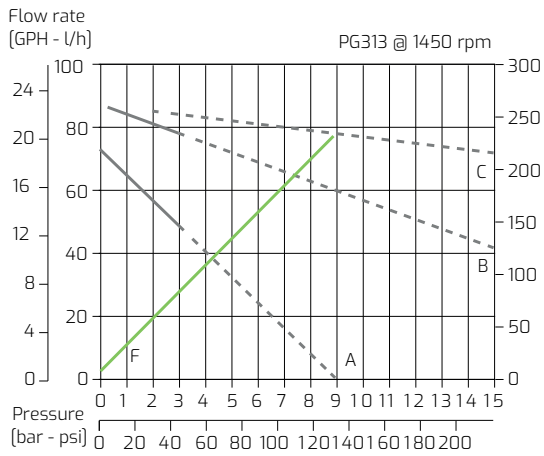

A = 1 cP B = 20 cP C = 75 cP D = 180 cP E = 210 cP F = 1 cP Torque
 — Operating range with ferrite driving magnet
 - - - Operating range with rare earth driving magnet
 — Torque

Note: Characteristics with water at 20 °C (68 F) and without relief valve. Fluids different from water must be validated by the Customer. Temperature requirements different from ambient temperature must be mentioned on the order. Different materials are available upon request. Use a filter before the pump inlet no larger than 10 micron

